

PANASONIC RELAYS

FOR PHOTOVOLTAIC POWER SOLUTIONS



LF-G Relay
1a 22A/31A 250V AC



JT-G Relay
1a 26A 250V AC



HE Relay PV
1a 35A/48A 250V AC









EP Relay 20A
1a 20A 1,000V DC



EP Relay 80A
1a 80A 1,000V DC

Relay applications

AC side

LF-G Standard	JT-G	LF-G High capacity	HE PV Standard	HE PV High capacity	HE 2 Form A (PCB type)
					
22A	26A	31A	35A	48A	27A

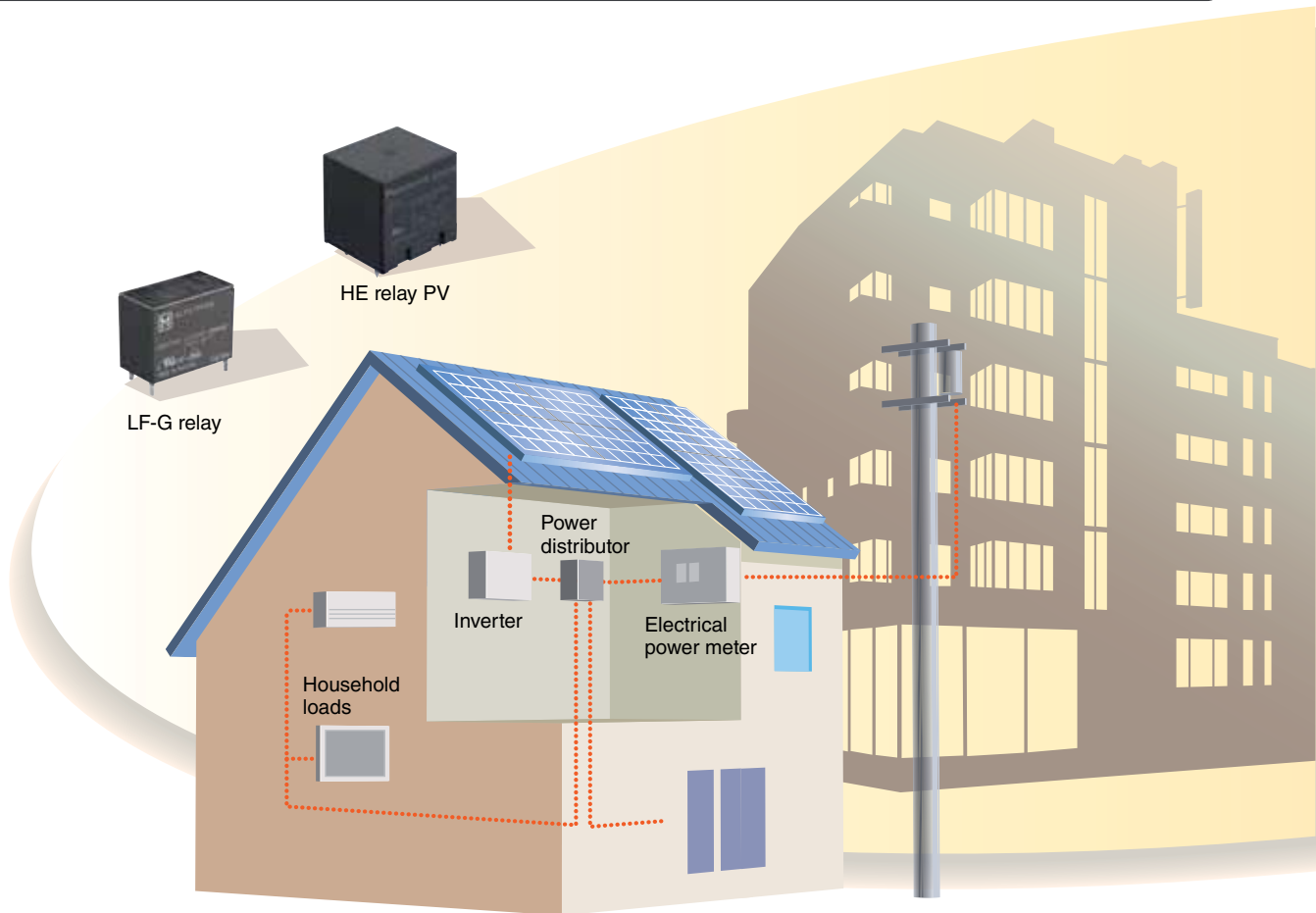



Application 1 Relay A (for safety shutoff on the AC side)

Relays are used for safety shutoff on the commercial power supply line (grid).

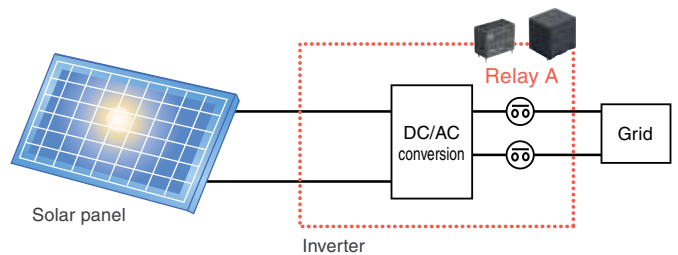
The relay must shut off the circuit to ensure safe disconnect from the public grid. Power relays are required as a safety measure to protect the power supply system.



DC side

EP 10A (TM type)	EP 10A (PCB type)	EP 20A	EP 80A	EP 300A
				
10A	10A	20A	80A	300A

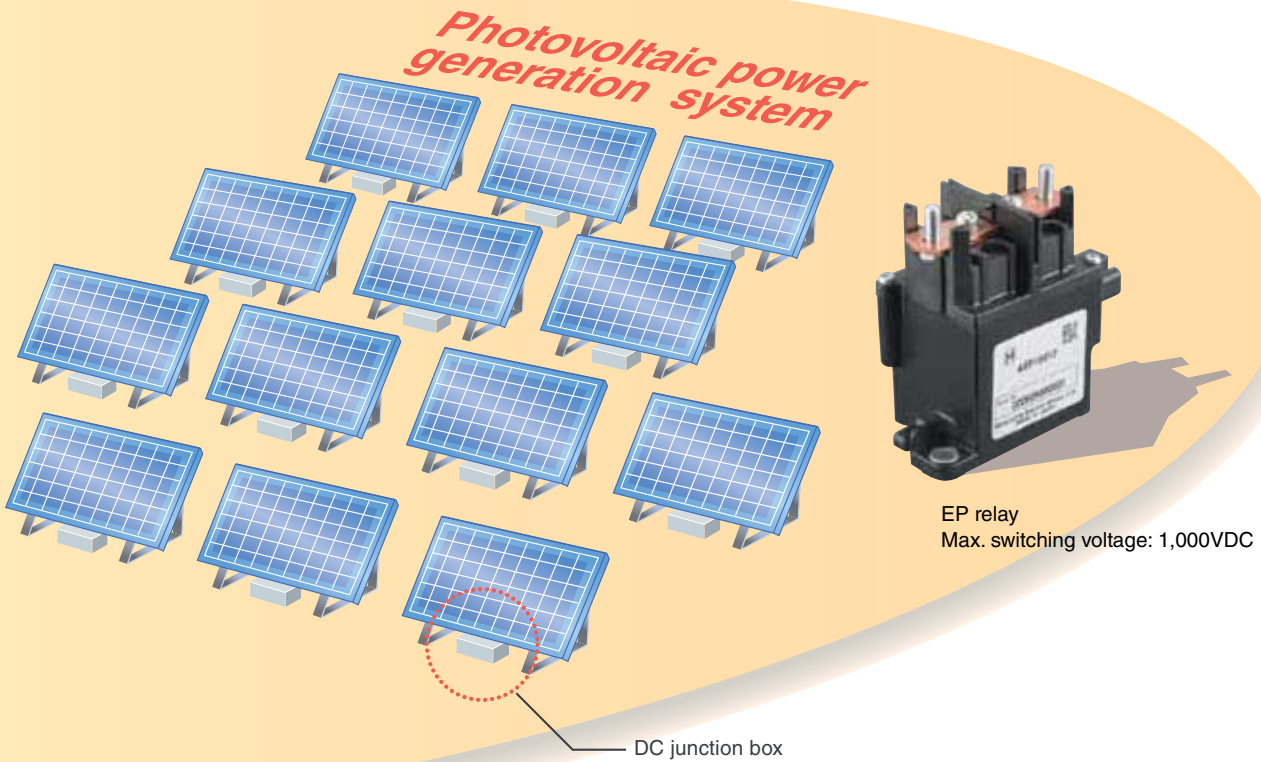

Application 1 Relay B (detection of the solar position)

When the inclination is calibrated, relay B is turned on and relay C is turned off.





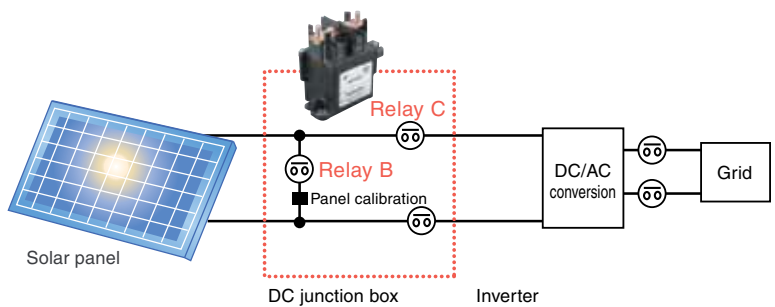

The current generated is detected by a current sensor and the inclination of solar panels is calculated and optimized.

Application 2 Relay C (safety shutoff on the DC side)

Instead of manual breakers, many such relays are used in various fields. They must be able to control high voltages remotely.

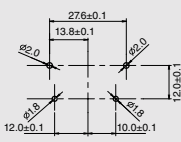
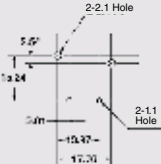
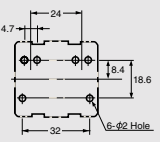
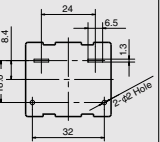
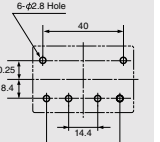
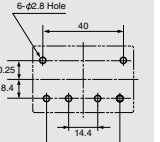

AC side

		AC side					
Market		Residential, commercial			commercial		
Output (Inverter)		1~4kW	5~7kW	1~4kW	8~10kW		
Corresponding relay		LF-G Standard 	LF-G High capacity 	JT-G  Under development	HE PV Standard 	HE PV High capacity 	HE 2 Form A PCB type 
Contact	Arrangement	1a		1a	1a		2a
	Nominal switching capacity	22A 250VAC	31A 250VAC	26A 250VAC	35A 250VAC 35A 30VDC *1	48A 250VAC 48A 30VDC *1	27A 250VAC
	Contact GAP	1.5mm *7		1.85mm	2.5mm		3.0mm
Coil	Coil voltage (DC)	9, 12, 18, 24 V		12 V	9 V	6, 9, 12, 24 V	9.24 V
	Nominal operating power	1,400mW		1,000mW	1,920mW		1,920mW
	Coil holding voltage *2 (Max. contact carrying current: at 20°C)	170mW 35%V of nominal coil voltage at 20°C		*5	310mW 40%V of nominal coil voltage at 20°C		310mW 40%V of nominal coil voltage at 20°C
Breakdown voltage (Between contact and coil)		4,000VAC		3,500VAC	5,000VAC		5,000VAC
Size (mm)		15.7(L)×30.1(W)×23.3(H)		26.9(L)×31.9(W)×20.2(H)	33(L)×38(W)×36.3(H)		33(L)×50(W)×39(H)
Terminal layout (Bottom view)		 General tolerance ±0.1	 General tolerance ±0.1	 General tolerance ±0.1	 General tolerance ±0.1	 General tolerance ±0.1	 General tolerance ±0.1
Ambient temperature		-40°C~+85°C *3		-55°C~+85°C *6	-50°C~+85°C *4		-50°C~+80°C *4
Standards		UL, C-UL, VDE					VDE
RoHS		RoHS compliant					

*1 The IGBT must be combined with HE relay in order to incorporate the DC breaker function into an inverter.

The switching is carried out on the IGBT and the relay is used only for conduction.

*2 Coil holding voltage is set following a 100ms-start pulse of the nominal coil voltage.

*3 When applied, coil holding voltage is 45% to 80% of nominal coil voltage.





*4 When applied, coil holding voltage is 50% to 60% of nominal coil voltage.

*5 250mW 50%V of nominal voltage at 85°C.

*6 For 50% to 70%V of nominal coil voltage.

*7 1.8mm is under development.

DC side

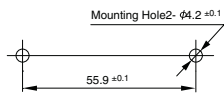
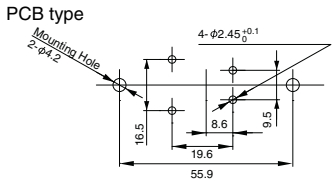
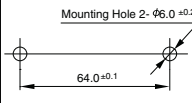
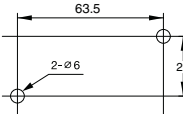
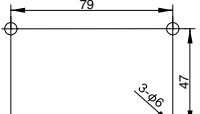
		DC side			
Market		Residential commercial, power plant			
Corresponding relay		<p>EP 10A</p>  <p>TM type PCB type</p>	<p>EP 20A</p>  <p>Under development</p>	<p>EP 80A</p> 	<p>EP 300A</p> 
Contact	Arrangement	1a	1a	1a	1a
	Nominal switching capacity	10A, 400VDC	20A, 400VDC	80A, 400VDC	300A, 400VDC
	Max. switching voltage	1,000VDC			
Coil	Coil voltage (DC)	12, 24, 48, 100 V	12 V	12, 24 V	12, 24 V
	Nominal operating power	1.4W or less	3.9W	5W or less	When input: 40W max. (0.1 sec. from time of input when retained: 4W max)
Breakdown voltage (Between contact and coil)		2,500VAC			
Size (mm)		37.9(L)×62.4(W)×31.3(H) (PCB) 37.9(L)×66.8(W)×31.7(H) (TM)	40(L)×78(W)×48.1(H)	40(L)×75.5(W)×79(H)	63(L)×111(W)×74.7(H)
Terminal layout (Bottom view)		<p>TM type</p>  <p>PCB type</p> 	<p>Mounting Hole 2-$\phi 6.0^{+0.2}$</p>  <p>General tolerance ± 0.1</p>	<p>63.5</p>  <p>2-$\phi 6$</p> <p>26</p> <p>General tolerance ± 0.1</p>	<p>79</p>  <p>3-$\phi 6$</p> <p>47</p> <p>General tolerance ± 0.1</p>
Ambient temperature		-40°C~+80°C			
Options		-	-	Terminal protection cover is available (please contact us)	
Standards		C-UL	-	C-UL	-
RoHS		RoHS compliant			

Panasonic Relays for Photovoltaic Power Solutions

Ordering information

LF-G relay

Standard packing: Carton, 50 pcs.; Case, 200 pcs.

Arrangement	Nominal coil voltage	Part No.	
		Standard	High capacity
1a	DC9V	ALFG1PF09	ALFG2PF09
	DC12V	ALFG1PF12	ALFG2PF12
	DC18V	ALFG1PF18	ALFG2PF18
	DC24V	ALFG1PF24	ALFG2PF24

HE relay PV

Standard packing: Carton, 20 pcs.; Case, 100 pcs.

Arrangement	Nominal coil voltage	Part No.	
		Standard	High capacity
1a	DC6V	—	HE1aN-P-DC6V-Y5
	DC9V	HE1aN-P-DC9V-H18	HE1aN-P-DC9V-Y5
	DC12V	—	HE1aN-P-DC12V-Y5
	DC24V	—	HE1aN-P-DC24V-Y5

EP relay

Standard packing: 10A Carton, 25 pcs.; Case, 100 pcs.;
80A Carton, 1 pc.; Case, 20 pcs.; 300A Carton, 1 pc.; Case, 5 pcs.

Arrangement	Type	Nominal coil voltage	Part No.
1a	10A PCB type	DC12V	AEP31012
		DC24V	AEP31024
		DC48V	AEP31048
		DC100V	AEP310X0
	10A TM type	DC12V	AEP51012
		DC24V	AEP51024
		DC48V	AEP51048
		DC100V	AEP510X0
	80A	DC12V	AEP18012
		DC24V	AEP18024
	300A	DC12V	AEP19012
		DC24V	AEP19024

JT-G relay, HE relay 2 Form A PCB type, EP relay 20A, EP relay terminal covers are available. Please contact us.

LF-G/JT-G/HE relays

- Suitable for European photovoltaic generation standard VDE0126.
- Suitable for international photovoltaic generation standard IEC 62109.

LF-G relay



1.8mm*

HE relay
PV type



2.5mm

JT-G relay



1.85mm

HE relay
2 Form A
PCB type



2.5mm

* 1.5mm is standard, 1.8mm is under development

Panasonic Relays for Photovoltaic Power Solutions

LF-G/JT-G/HE relay PV features

Contributes to energy saving in devices with reduced coil holding voltage

For most existing products, nominal coil voltage has to be applied to the coil side. However, the LF-G, JT-G and HE PV relays can be operated with reduced coil voltage (coil holding voltage *1), lowering power consumption.

Condition: max. contact carrying current at 20°C (LF-G, HE), 85°C (JT-G)

Product	Nominal operating power	Coil holding voltage	Holding power
LF-G relay	1,400mW	35% of nominal coil voltage	approx. 170mW
JT-G relay	1,000mW	50% of nominal coil voltage	approx. 250mW
HE relay PV	1,920mW	40% of nominal coil voltage	approx. 310mW

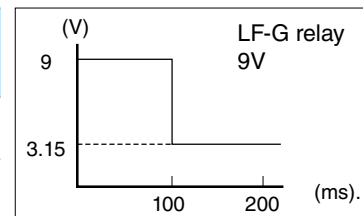

*1 Coil holding voltage is set following a 100ms-start pulse of the nominal coil voltage.

How to reduce coil holding voltage

One way to achieve low holding power is to set the coil holding voltage following a 100ms-start pulse of the nominal coil voltage, or establish the following conditions.

1) LF-G relay

- Sample: **ALFG1PF09** (9V type)
- Circuit

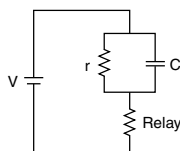

3. Recommended condition (ambient temperature: 20°C)

Coil applied voltage	Coil holding voltage	R (Relay)	C	r	Inrush time	Time until nominal voltage	Voltage in operate time	Operate time		
[V]	[%V]	[V]	[%V]	[Ω]	[μF]	[Ω]	[ms]	[ms]		
12	133.3	4.05	45.0	58.0	640	113.9	107.5	15.0	11.1	4.50
12	133.3	4.05	45.0	58.0	470	113.9	95.5	10.5	11.0	4.54
10.8	120.0	4.05	45.0	58.0	640	96.7	99.0	10.0	10.1	4.98

Wave of coil voltage

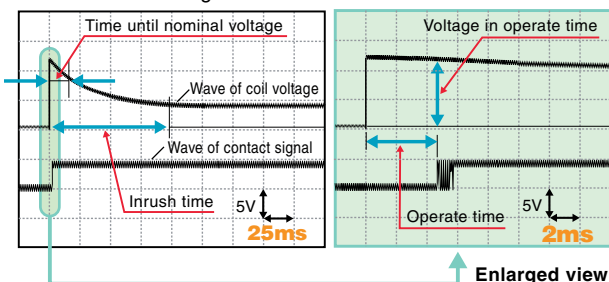

2) HE relay PV

- Sample: **HE1aN-P-DC9V-Y5** (9V type)
- Circuit

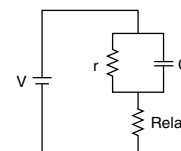

3. Recommended condition (ambient temperature: 20°C)

Coil applied voltage	Coil holding voltage	R (Relay)	C	r	Inrush time	Time until nominal voltage	Voltage in operate time	Operate time		
[V]	[%V]	[V]	[%V]	[Ω]	[μF]	[Ω]	[ms]	[ms]		
12	133.3	4.5	50.0	42.2	640	70.3	76.5	18.0	10.0	11.85

Wave of coil voltage

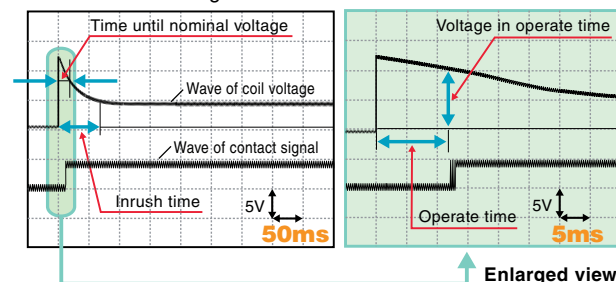

* For LF-G, it takes 2 times as long for the nominal voltage to activate the coil than the operate time itself. For HE PV, it takes 1.5 times as long for the nominal voltage to activate the coil than the operate time itself. This method for reducing the coil holding voltage is only a reference and cannot be guaranteed. Please check actual operation under the most stringent conditions in the actual application.

EP relay features

EP Relay

The EP relay is a compact power relay that enables high DC voltage and a high current interruption. Compared to conventional DC contactors for existing products generally used in the high DC voltage applications, here are some advantages the EP relay offers.

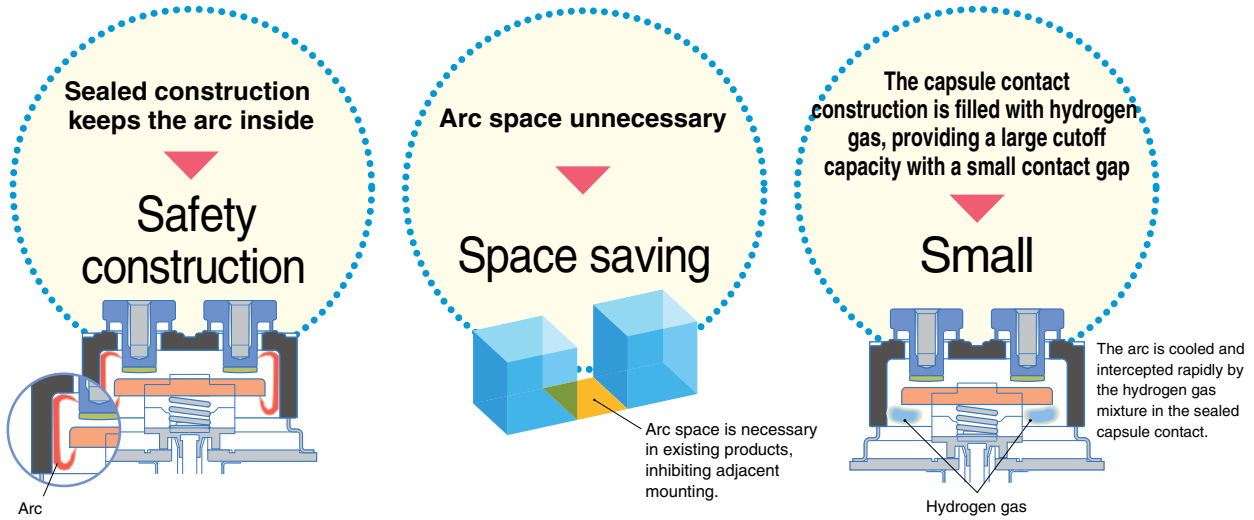

Operation (interception mechanism)

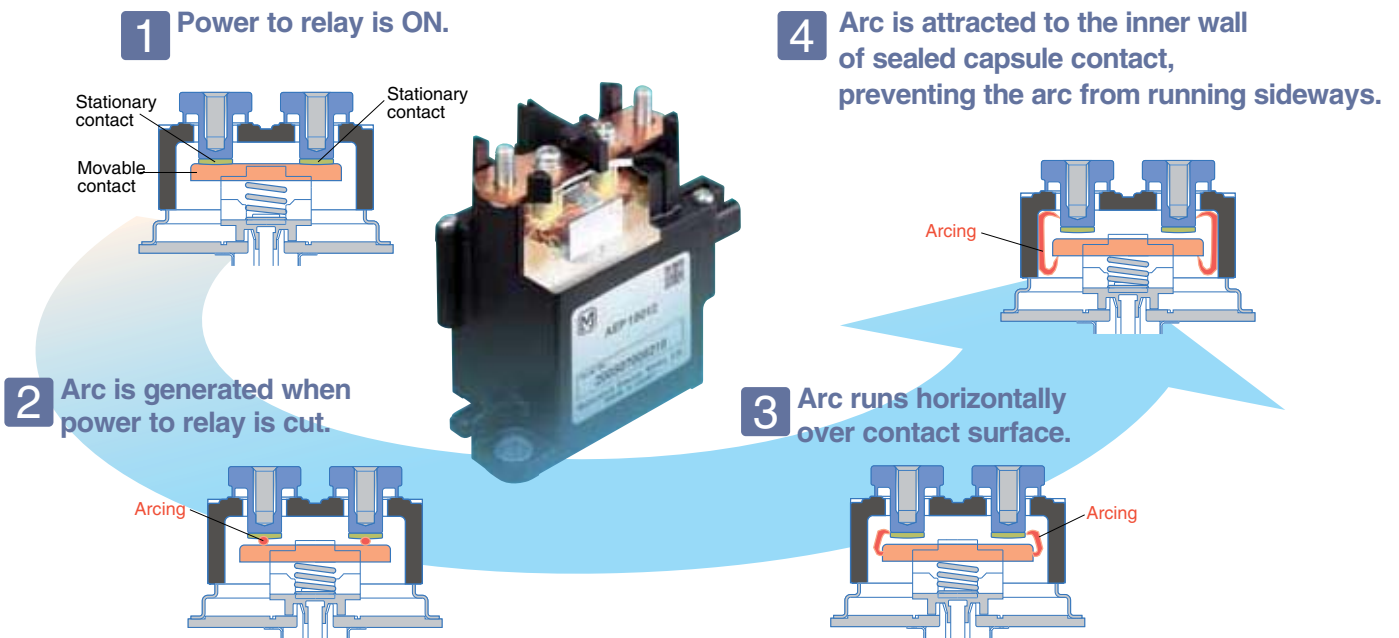

EP relay options

Terminal protect cover (80A, 300A only)

“Terminal protect covers” reduce high DC voltage risks (80A, 300A only) and are now available. Please contact us.

- Terminal protect cover
80A type



- 300A type



Terminal protect cover on relay



80A type

- Dimensions (Unit: mm)
80A type

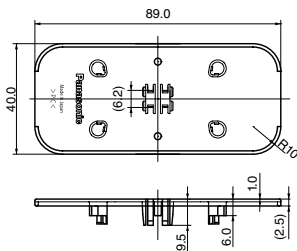

- 300A type

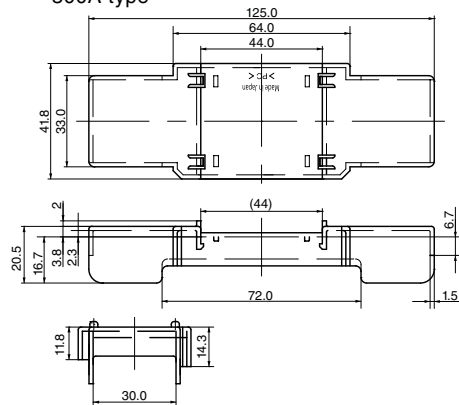

300A type



Lead wire type (input side) (80A only)

A lead wire type is available to prevent insulation problems from occurring with adjacent components.

For high voltage risks near the input side.

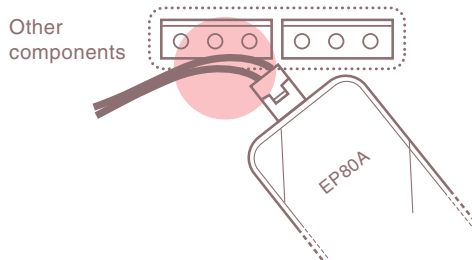

Insulation distance is not sufficient with existing connector type.

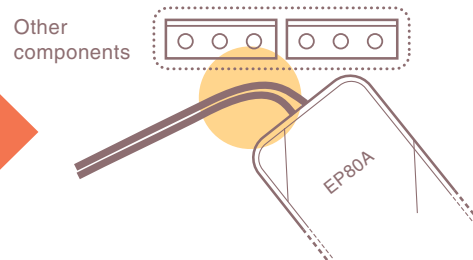

Sufficient insulation distance can be created with lead wire type.

EP relay estimated life (cycles)

Reference data

Note: Please test under actual conditions before use.

— 1,000VDC — 800VDC
— 600VDC — 400VDC

10A type

Make and break (switching) possible below 10A

Breaks only above 10A

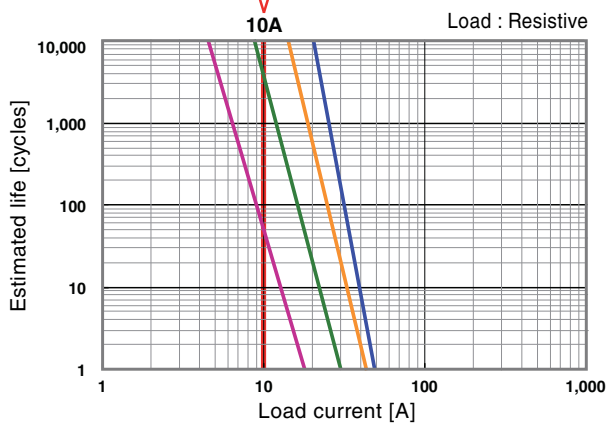

20A type

Make and break (switching) possible below 20A

Breaks only above 20A

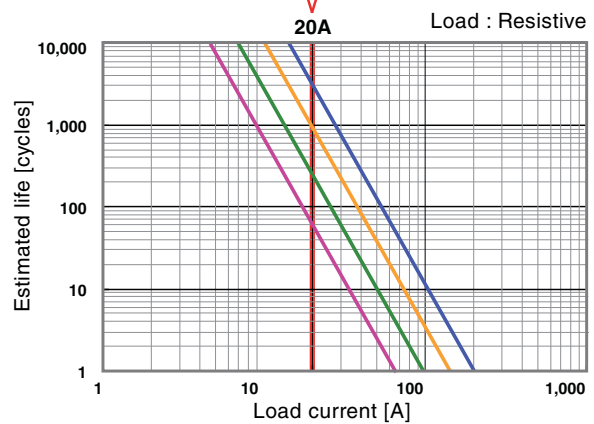

80A type

Make and break (switching) possible below 80A

Breaks only above 80A

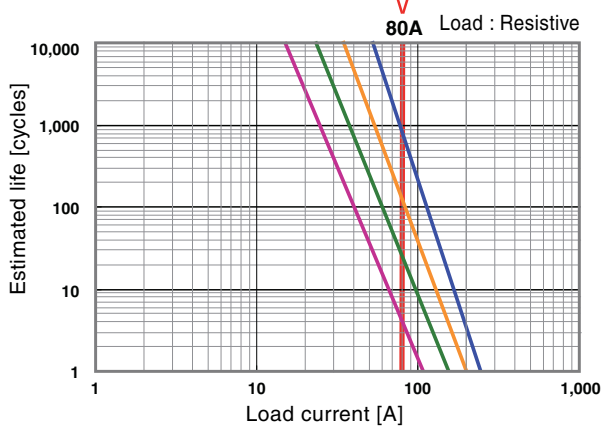

300A type

Make and break (switching) possible below 300A

Breaks only above 300A

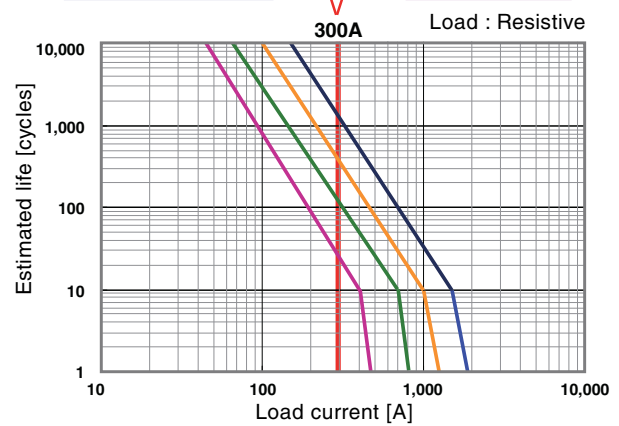

North America

Europe

Asia Pacific

China

Japan

Panasonic Electric Works

Please contact our Global Sales Companies in:

Europe		
▶ Headquarters	Panasonic Electric Works Europe AG	Rudolf-Diesel-Ring 2, 83607 Holzkirchen, Tel. +49 (0) 8024 648-0, Fax +49 (0) 8024 648-111, www.panasonic-electric-works.com
▶ Austria	Panasonic Electric Works Austria GmbH	Josef Madersperger Str. 2, 2362 Biedermansdorf, Tel. +43 (0) 2236-26846, Fax +43 (0) 2236-46133 www.panasonic-electric-works.at
	PEW Electronic Materials Europe GmbH	Ennschafenstraße 30, 4470 Enns, Tel. +43 (0) 7223 883, Fax +43 (0) 7223 88333, www.panasonic-electronic-materials.com
▶ Benelux	Panasonic Electric Works Sales Western Europe B.V.	De Rijn 4, (Postbus 211), 5684 PJ Best, (5680 AE Best), Netherlands, Tel. +31 (0) 499 372727, Fax +31 (0) 499 372185, www.panasonic-electric-works.nl
▶ Czech Republic	Panasonic Electric Works Czech s.r.o.	Sales Office Brno, Administrative centre PLATINIUM, Veverí 111, 616 00 Brno, Tel. (+420-) 374 799 990, Fax (+420-) 374 799 999, www.panasonic-electric-works.cz
▶ France	Panasonic Electric Works Sales Western Europe B.V.	Succursale française, 10, rue des petits ruisseaux, 91370 Verrières Le Buisson, Tél. +33 (0) 1 6013 5757, Fax +33 (0) 1 6013 5758, www.panasonic-electric-works.fr
▶ Germany	Panasonic Electric Works Europe AG	Rudolf-Diesel-Ring 2, 83607 Holzkirchen, Tel. +49 (0) 8024 648-0, Fax +49 (0) 8024 648-111, www.panasonic-electric-works.de
▶ Hungary	Panasonic Electric Works Europe AG	Magyarországi Közvetlen Kereskedelmi Képviselet, 1117 Budapest, Neumann János u. 1., Tel. +36 1 999 89 26 www.panasonic-electric-works.hu
▶ Ireland	Panasonic Electric Works UK Ltd.	Irish Branch Office, Dublin, Tel. +353 (0) 14600969, Fax +353 (0) 14601131, www.panasonic-electric-works.co.uk
▶ Italy	Panasonic Electric Works Italia srl	Via del Commercio 3-5 (Z.I. Ferlina), 37012 Bussolengo (VR), Tel. +39 (0) 456752711, Fax +39 (0) 456700444, www.panasonic-electric-works.it
▶ Nordic Countries	Panasonic Electric Works Nordic AB	Knarrarnäsgatan 15, 164 40 Kista, Sweden, Tel. +46 859476680, Fax +46 859476690, www.panasonic-electric-works.se
▶ Poland	Panasonic Electric Works Polska sp. z o.o	Jungmansgatan 12, 21119 Malmö, Tel. +46 40 697 7000, Fax +46 40 697 7099, www.panasonic-fire-security.com
▶ Portugal	Panasonic Electric Works España S.A.	ul. Wołoska 9A, 02-583 Warszawa, Tel. +48 (0) 22 338-11-33, Fax +48 (0) 22 338-12-00, www.panasonic-electric-works.pl
▶ Spain	Panasonic Electric Works España S.A.	Portuguese Branch Office, Avda Adelino Amaro da Costa 728 R/C J, 2750-277 Cascais, Tel. +351 214812520, Fax +351 214812529
▶ Switzerland	Panasonic Electric Works Schweiz AG	Barajas Park, San Severo 20, 28042 Madrid, Tel. +34 913293875, Fax +34 913292976, www.panasonic-electric-works.es
▶ United Kingdom	Panasonic Electric Works UK Ltd.	Grundstrasse 8, 6343 Rotkreuz, Tel. +41 (0) 41 7997050, Fax +41 (0) 41 7997055, www.panasonic-electric-works.ch
		Sunrise Parkway, Linford Wood, Milton Keynes, MK14 6 LF, Tel. +44 (0) 1908 231555, Fax +44 (0) 1908 231599, www.panasonic-electric-works.co.uk
North & South America		
▶ USA	PEW Corporation of America	629 Central Avenue, New Providence, N.J. 07974, Tel. 1-908-464-3550, Fax 1-908-464-8513, www.pewa.panasonic.com
Asia Pacific/China/ Japan		
▶ China	Panasonic Electric Works (China) Co., Ltd.	Level 2, Tower W3, The Towers Oriental Plaza, No. 2, East Chang An Ave., Dong Cheng District, Beijing 100738, Tel. (010) 5925-5988, Fax (010) 5925-5973
▶ Hong Kong	Panasonic Electric Works (Hong Kong) Co., Ltd.	RM1205-9, 12/F, Tower 2, The Gateway, 25 Canton Road, Tsimshatsui, Kowloon, Hong Kong, Tel. (0852) 2956-3118, Fax (0852) 2956-0398
▶ Japan	Panasonic Electric Works Co., Ltd.	1048 Kadoma, Kadoma-shi, Osaka 571-8686, Japan, Tel. (06) 6908-1050, Fax (06) 6908-5781, http://panasonic-electric-works.net
▶ Singapore	Panasonic Electric Works Asia Pacific Pte. Ltd.	101 Thomson Road, #25-03/05, United Square, Singapore 307591, Tel. (06255) 5473, Fax (06253) 5689