



PCB type



TMP type

FEATURES

- Surge withstand voltage: Min. 6,000 V
- High switching capacity — 30 A for 1 Form A
- 2 contact arrangements — 1 Form A or 1 Form C
- “TMP” types available
- UL/C-UL recognized
- Class F types standard

SPECIFICATIONS

Contacts

		PCB & TMP type	
Arrangement		1 Form A	1 Form C
Initial contact resistance, max. (By voltage drop method, 6 V DC 1 A)		50 mΩ	
Contact material		AgSnO ₂ type	
Rating	Max. switching power	8310 VA	N.C.: 2770 VA N.O.: 5540 VA
	Max. switching voltage	277 V AC	
	Max. switching current	30 A	N.C.: 10 A N.O.: 20 A
	Min. switching capacity ^{#1}	100 mA, 5 V DC	
Expected life	Mechanical	Min. 1×10 ⁷	
	Electrical (Resistive load)	20 A 277 V AC Min. 1×10 ⁵ *	N.O.: 20 A 277 V AC Min. 1×10 ⁵ * N.C.: 10 A 277 V AC Min. 1×10 ⁵ *

* The life is for open venting-hole condition.

Coil at 20°C 68°F

	PCB & TMP type
Nominal operating power	Approx. 1,000 mW

Characteristics

		PCB & TMP type
Initial insulation resistance ^{*1}		Min. 100 MΩ at 500 V DC
Initial breakdown voltage ^{*2}	Between contacts	1,200 Vrms
	Between contacts and coil	3,500 Vrms
Initial surge voltage between contact and coil		Min. 6,000 V ^{*3}
Operate time ^{*4} (at nominal voltage)		Max. 15 ms
Release time (without diode) ^{*4} (at nominal voltage)		Max. 10 ms
Shock resistance	Functional ^{*5}	Min. 98 m/s ² {10 G}
	Destructive ^{*6}	Min. 980 m/s ² {100 G}
Vibration resistance	Functional ^{*7}	Max. 88.2 m/s ² {9 G}, 10 to 55 Hz at double amplitude of 1.5 mm
	Destructive	Max. 117.6 m/s ² {12 G}, 10 to 55 Hz at double amplitude of 2 mm
Conditions for operation, transport and storage ^{*8} (Not freezing and condensing at low temperature)	Ambient temp.	-55°C to +85°C -67°F to +185°F
	Humidity	5 to 85% R.H.
Unit weight		PCB type: Approx. 25 g (.88 oz) TMP type: Approx. 30 g (1.06 oz)

#1 This value can change due to the switching frequency, environmental conditions, and desired reliability level, therefore it is recommended to check this with the actual load.

Remarks

- * Specifications will vary with foreign standards certification ratings.
- *¹ Measurement at same location as “Initial breakdown voltage” section
- *² Detection current: 10 mA
- *³ Ware is standard shock voltage of $\pm 1.2 \times 50\mu\text{s}$ according to JEC-212-1981.
- *⁴ Excluding contact bounce time
- *⁵ Half-wave pulse of sine wave: 11ms; detection time: 10μs
- *⁶ Half-wave pulse of sine wave: 6ms
- *⁷ Detection time: 10μs
- *⁸ Refer to “6. Usage, Storage and Transport Conditions” in **AMBIENT ENVIRONMENT** section in [Relay Technical Information](#).

TYPICAL APPLICATIONS

- Oven
- Heating & ventilation
- Home appliance

ORDERING INFORMATION

JT-V Relays (PCB and TMP type)

JTV		1a	S	TMP	12V
Contact arrangement	Protective construction	Mounting classification	Coil voltage		
1a: 1 Form A 1: 1 Form C	S: Sealed type G: Dust cover type	PA: PCB type TMP: TMP type	DC 12, 18, 24, 48 V		

- Notes: 1. UL/C-UL approved type is standard.
 2. 5 V, 6 V, 9 V DC types are also available. Please contact us for details.
 3. Standard packing: PCB type: Carton: 50 pcs. Case: 500 pcs.
 TMP type: Carton: 50 pcs. Case: 300 pcs.

COIL DATA (at 20°C 68°F)

Nominal voltage, V DC	Pick-up voltage, V DC (max.) (Initial)	Drop-out voltage, V DC (min.) (Initial)	Coil resistance, Ω ($\pm 10\%$)	Nominal operating power, mW	Max. allowable voltage, V DC (at 70°C 158°F)
			PCB & TMP	PCB & TMP	
12	9.0	1.2	144	1000	14.4
18	13.5	1.8	324	1000	21.6
24	18.0	2.4	576	1000	28.8
48	36.0	4.8	2304	1000	57.6

DIMENSIONS (mm inch)

Download [CAD Data](#) from our Web site.

CAD Data

1. PCB type

1 Form A

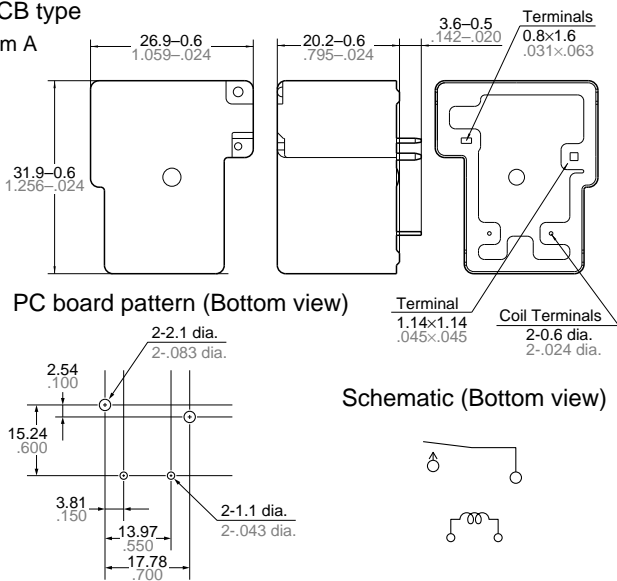

1 Form C

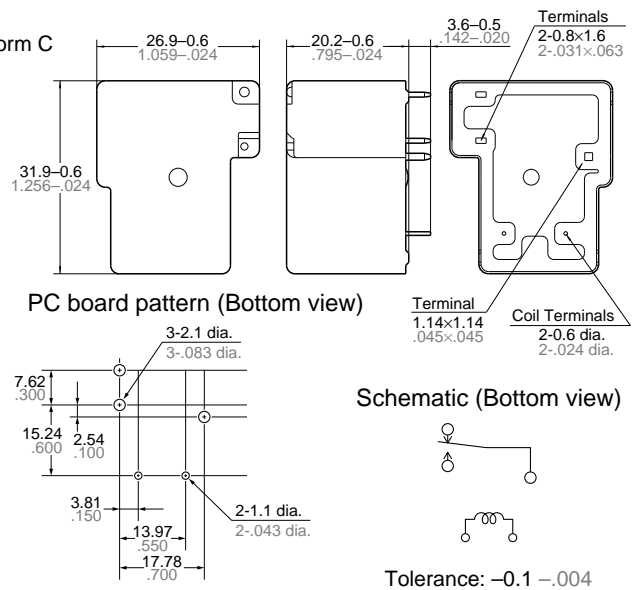

CAD Data

2. TMP type

1 Form A

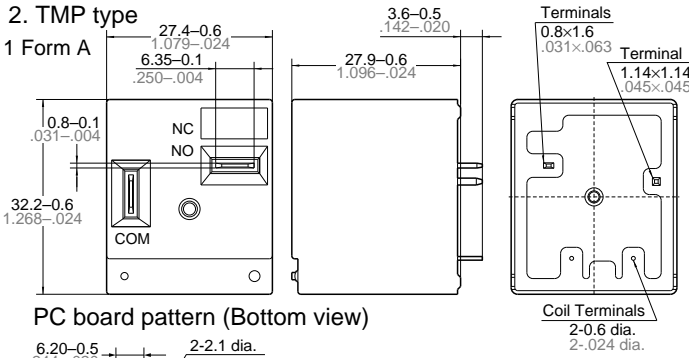

1 Form C

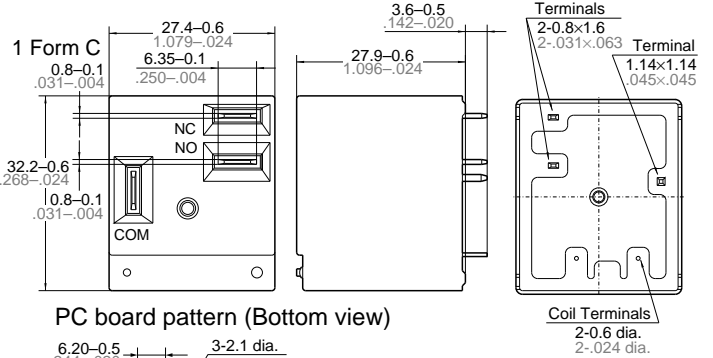

PC board pattern (Bottom view)

PC board pattern (Bottom view)

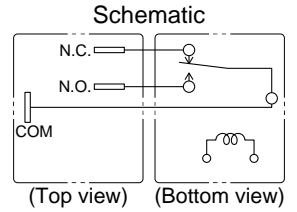
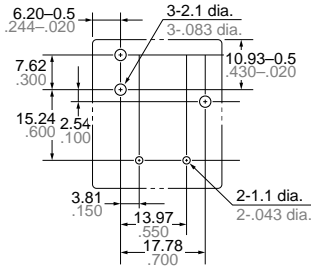
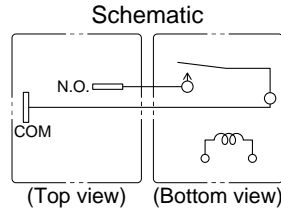
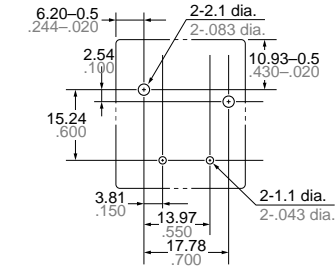

Tolerance: -0.1 - .004

REFERENCE DATA

1. Change of rate of pick-up and drop-out voltage (at 20°C 68°F)
Sample: JTV1S-TMP-24V (6 pcs.)

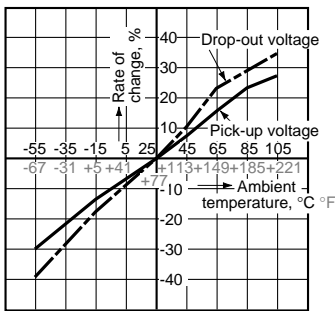

2. Distribution frequency of pick-up voltage (at 20°C 68°F)
Sample: JTV1S-TMP-12V (100 pcs.)

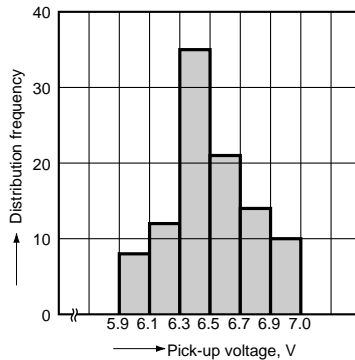

3. Distribution frequency of drop-out voltage (at 20°C 68°F)
Sample: JTV1S-TMP-12V (100 pcs.)

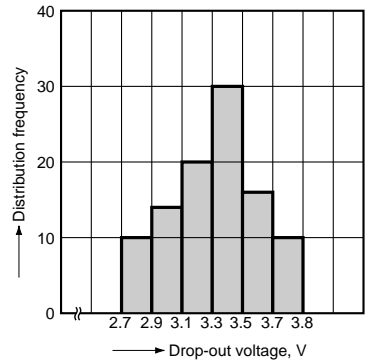

4.-(1) Coil temperature rise (TMP type)*
Ambient temperature: 25°C 77°F
Sample: JTV1aS-TMP-12V (6 pcs.)

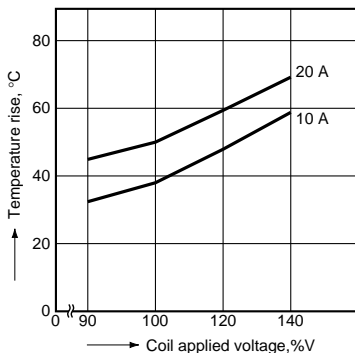

Ambient temperature: 85°C 185°F
Sample: JTV1aS-TMP-12V (6 pcs.)

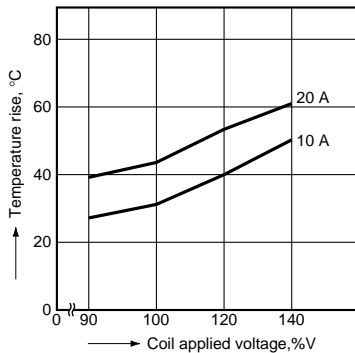

* Coil temperature rise of sealed types are same as data of the dust cover type.

SAFETY STANDARDS

Item	UL/C-UL (Recognized)	
	File No.	Contact rating
1 Form A	E43028	30A 277V AC, 30A 28V DC, 2HP 250V AC
1 Form C	N.O.	20A 277V AC, 20A 28V DC, 2HP 250V AC
	N.C.	10A 277V AC, 10A 28V DC, 1/2HP 250V AC

* CSA standard: Certified by C-UL

For Cautions for Use, see [Relay Technical Information](#).